

Vision is  
our mission®

Camera HMOS 180° DigiCoax  
Article no. 0185000

Camera HMOS 120° DigiCoax  
Article no. 0185010

Camera HMOS 90° DigiCoax  
Article no. 0185020

Camera HMOS 60° DigiCoax  
Article no. 0185030

Camera HMOS 30° DigiCoax  
Article no. 0185040

2017 • DS0961402 EN A 01



# Product Data

## Dimensions

Only by  
Art. no. 0185000  
this size is 24mm

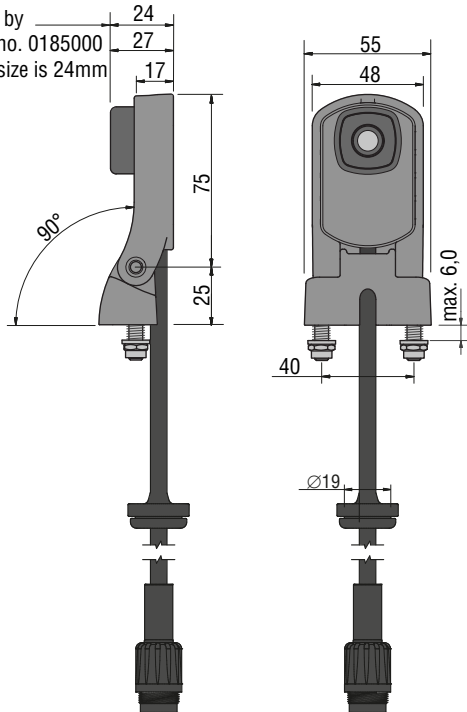

Units in mm

## Mounting options

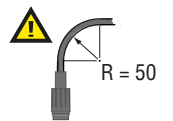
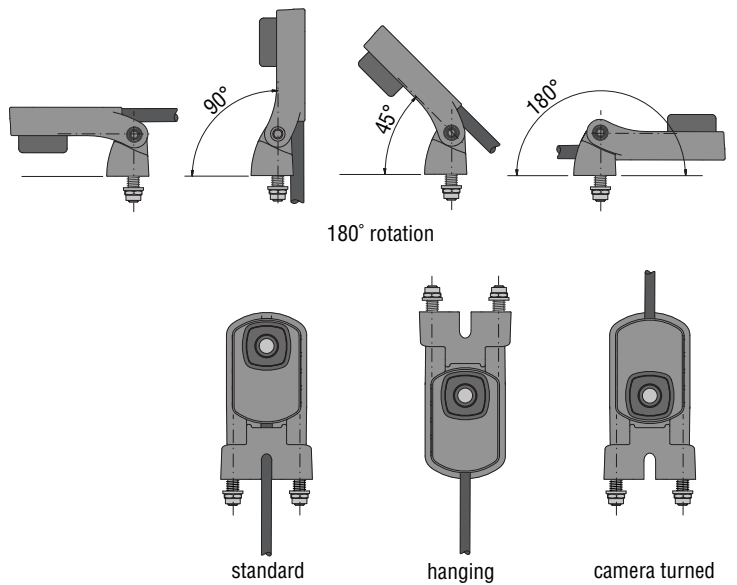

Min. bend radius= 50mm

## TECHNICAL DATA

### Camera HMOS DigiCoax

	Description	0185000	0185010	0185020	0185030	0185040
Articlenumber		0185000	0185010	0185020	0185030	0185040
Lens Specified		HMOS 180°	HMOS 120°	HMOS 90°	HMOS 60°	HMOS 30°
Horizontal lens angle		180°	120°	90°	60°	30°
Vertical len angle		105°	74°	56°	37°	18,5°
Sensor element		High resolution 1/3" CMOS rolling shutter, 1280H x 960V.				
Video image		50 fps SDR/HDR 1280 X 800.				
Protocols		Uncompressed video over coax.				
Latency		<6µs				
Light sensitivity		Responsivity 5.5V/lux-sec, Low light feature (<0,1 Lux).				
High Dynamic Range		>115dB.				
Interface		DigiCoax.				
Image processing		Color and gamma correction, 3D noise correction, edge enhancement, digital WDR, advanced contrast enhancement, auto white-balance, auto exposure control, mirroring, flipping, photometric and geometric lens distortion correction.				
		<b>Electrical</b>				
Power input		Camera HMOS may only be powered by Orlaco monitor HLED. The camera HMOS has no internal power protection.				
Power consumption		<2W				
Connector/Cable		0,5m cable with Coax and molded male connector (camera power input and video output).				
Min. cable bend radius		50mm.				
		<b>Mechanical</b>				
Housing		Anodised aluminium, black, UV resistant, light fastness >8, corrosion proof according IEC 60068-2-52 salt mist, cyclic.				
Filling		Camera is potted with automotive potting resin				
Ingress protection		IP68 according to IEC 60529; dust tight and protected against the effects of continuous immersion in water up to 10m under water for 30 minutes. IP69k according to DIN 40050-9: camera can withstand a high pressure cleaning with water: 14-16L/min. 80°C and 100 bars flow.				
Lens glass		Chemically hardened, toughed, tempered float glass: 5 to 7 times stronger than ordinary glass, protected against acid: class 2-3; DIN 12116, passed flying stone test.				
Mounting hardware		Standard stainless steel.				
Shock constancy		Shock and vibration resistant for usage on trucks, cranes, fork-lifts, maritime applications, machinery.				
Camera bracket		Material: Glass reinforced polyamide; VX4920 + PC/ABS; C1200HF, test: 50 Nm at -40°C to +85°C.				
Weight		0,24kg. including cable, bracket and mounting material. 0,30kg. in standard packing.				
Truck use		Withstand all fluids and materials used in and around trucks like: ammonia solution 5%, ethanol 80-100%, isopropanol 5-10%, soapy water (min. 50% soap per volume), alkaline degreasing compounds(used in high pressure washing equipment).				
Operating temperature		-40°C to +85°C.				
Storage temperature		-40°C to +125°C.				
		<b>Certification</b>				
Approvals		Approvals in compliance with all relevant EMC- and Automotive directives. This device complies with Part 15 of the FCC Rules. Operation is subject to the following conditions: (1) this device may not cause harmful interference, and (2) this device must accept any interference received, including interference that may cause undesired operation. Certificates available upon request. Compliant with RoHS and REACH.				

All data subject to change without notice. All dimensions are for commercial purpose only.

The camera/display systems from Orlaco comply with the latest CE, ADR, EMC and mirror-directive regulations, where applicable.

All products are manufactured in accordance with the ISO 9001 quality management system, ISO/TS 16949 quality automotive, ISO 14001 environmental management systems and all Ex products with the IECEx scheme and ATEX directives, where applicable.

